

Furnishing the Terrassenhaus

Mick Aaldering,
Industrial design engineering,
University of Twente,
The Netherlands

Introduction

The lack of care taken with which tenant furnish their outdoor spaces is normally not noticed by the public, but with such a public and famous building like the Terrassenhaus in Berlin, this can cause the diminishing of value of the building, and it impedes the story the building tries to tell.

To improve this, a more thought through outdoor furniture selection is needed. This bachelor thesis is carried out in cooperation with Loehr, a Berlin based furniture design company that also specializes in creative services. They initially have designed the interior of a part of the Terrassenhaus and have been aware of the outdoor furniture situation ever since.



Figure 1 The Terrassenhaus (Ghinițoiu, 2020)

Approach

First a comprehensive understanding of the Terrassenhaus was required. This was done by the review of relevant literature, visiting the building itself and interviewing an architect that works at the designing architecture firm. With this comprehensive understanding the first concepts could be ideated. These 4 concepts were developed further with the help from the analysis, and one was chosen to be developed further with simulations and a 1:1 technical model into a fully working prototype **Error! Reference source not found.** This prototype was then evaluated to confirm the fit with the Terrassenhaus.

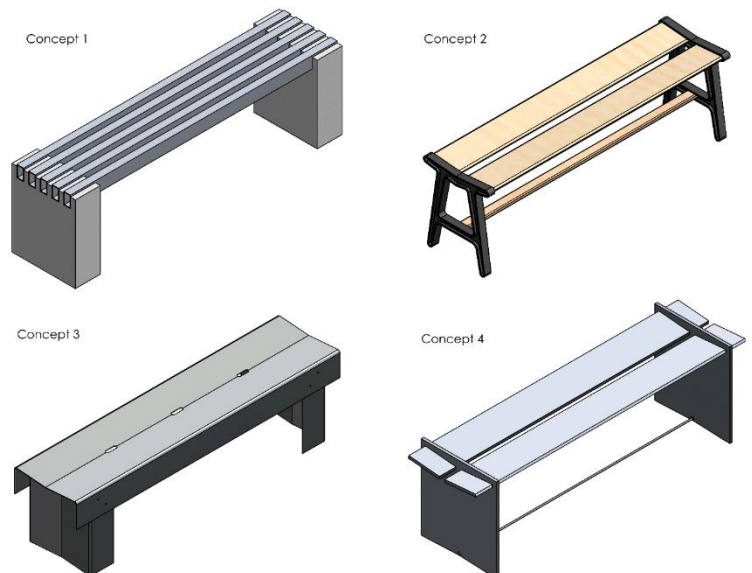

Figure 2 The four developed concepts (own work)

Result

The end result is a raw aluminium bench (concept 4 in **Error! Reference source not found.**) that embodies the design ethos (the value system with which something is designed) and narrative (story the building tries to tell) of the Terrassenhaus.

Following the design ethos means that the bench is designed with only pragmatic, non-aesthetic choices made, this is seen in

its simple construction and its lack of any ornamentation. The following of the narrative results in a bench that is extremely sturdy, easily changeable for a different scenario it needs to perform in. This changeability is due to its construction that fully relies on friction between the horizontal and vertical plates and the tension from the bottom cable. When the tension is removed, the parts are easily slid away from each other. This makes reusing the vertical plates for a smaller bench or even a stool extremely easy and makes adding other (yet to be developed) components easy.

This design is the basis for the further development of a set of furniture pieces that will transform the Terrassenhaus. This transformation hopes to achieve better coherence within the building and improvement of the clarity of the story the building is trying to tell.



Conclusion & recommendations

Figure 3 Final design proposal (own work)

It was concluded in the evaluation that the designed bench fits well with the Terrassenhaus. There were some questions raised by the questionnaire about the necessity of designing specific furniture for the building, rather than just getting a coherent furniture plan with off the shelf furniture. This would be the case if the building would not have such a strong narrative and the fact that designing for that narrative brings an added value to the building cannot be ignored. Therefore the specific designing of the bench is still adds significant value.

Further development would include bringing the design all the way to production (which includes producing a second prototype that is waterjet cut and finding producers for all processes) and development of additional parts like soft seating additions, several sizes of backrests, side tables, umbrella holders or plant potholders. Additionally, the further furnishment of the Terrassenhaus would start from this basis of design, which further would include tables and more lounge oriented furniture.

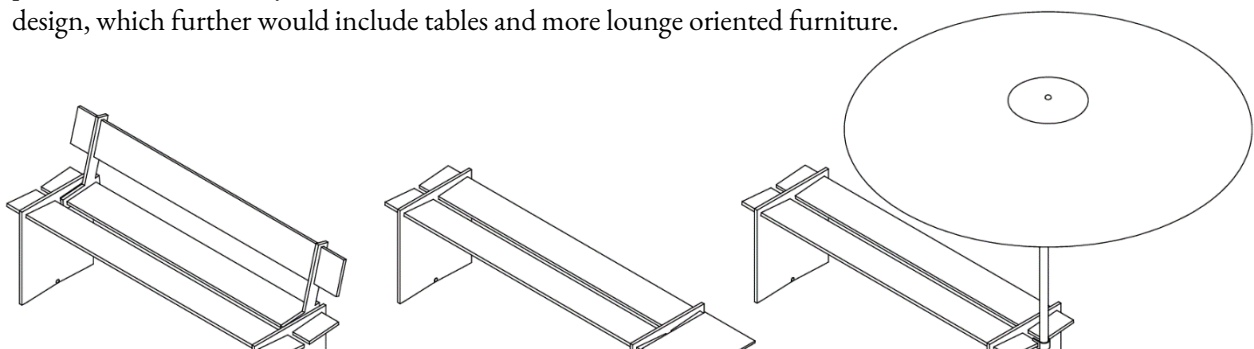

Figure 4 Possible additions to the design proposal (own work)

References

Ghinițoiu, L. (2020). *The Hill Made of Houses: Lobe Block, Berlin*. Retrieved from <https://e-zeppelin.ro/>:
<https://e-zeppelin.ro/en/the-hill-made-of-houses-lobe-block-berlin/>